

A STIFF NON-LINEAR ODE SIMULATION OF A BATCH/CONTINUOUS PLANT USING MATLAB/SIMULINK®

Guillermo A. Durand, J. Alberto Bandoni

Planta Piloto de Ingeniería Química, PLAPIQUI (UNS – CONICET)
Camino La Carrindanga, Km.7 (8000) Bahía Blanca, Argentina
TE: +54 291 486 1700 Interno 255, e-mail: gdurand@plapiqui.edu.ar

Keywords: Sugarhouse, Dynamic simulation, MATLAB/Simulink, non-linear ODE, stiffness

Abstract. *A sugarhouse is one stage in the production of beet sugar. The purpose of the sugarhouse is to crystallize and separate sugar from the thick juice obtained in previous stages. These crystallization and separation processes are carried out in batteries of batch units, while the upstream and downstream stages are continuous. The dynamics of such plant generate a highly non-linear model, and the sequencing of the batch and intra-batch operations makes the simulation a problem with heavy stiff characteristics.*

The simulation is an ODE problem and is carried out in a MATLAB/Simulink® environment. But the choice of the correct ODE solver depends on their performance to handle the model's stiff and non-linear characteristics. This project studies each ODE solver present in the Simulink suite. The study will consider also how the solver parameters affect its capacity to solve this simulation problem.

The final purposes of the sugarhouse simulation are: a) provide a test-bed where to apply proposed schedules for the batch units in order to obtain the optimal operation, and b) generate a training tool for operators and plant managers.

INTRODUCTION

In the production of sugar from beets, the process is carried out in several stages, called *houses*. Between these houses the most important is the sugarhouse, because it is the bottleneck of the production and has great impact in the total performance and economy of the total plant.

In the sugarhouse the sugar is crystallized from a thick juice which contains sugar, water and impurities (*non-sugars*). In most cases the crystallization is done batch wise in huge vessels of tons-per-cycle sizes, using steam to heat the juice and evaporate water, concentrating the sugar which crystallizes. While the crystallization is done in batch mode, the upstream and downstream processes are continuous. The transition between these production modes is solved inserting storage tanks, but there are several operation scenarios that can give storage problems. This is further complicated when the total sugarhouse is considered, with all its flow recycles, available utilities and product requirements.

As an evaporation-based crystallization, this process is energy and time consuming, and any non-optimal operation or malfunction generates big profit losses¹. So, it is very important to have robust and well-proven scheduling strategies to handle the batch cycles. Also, the operators controlling the process have to be well-trained in dealing with problems that can arise in the operation of the sugarhouse.

To address these requirements, a sugarhouse dynamic simulator has to be developed, in order to provide a virtual environment to train operators, where they can try several operation scenarios and make errors without causing profit losses. Also, the simulator can be utilized as a test-bed to try algorithm generated solutions for the scheduling problem.

A dynamic simulation is basically an ODE Initial Values problem, where a set of differential and algebraic equations must be solved over the selected period of time with an ODE solver. For the sugarhouse, its ODE problem can be solved only with a numeric ODE solver, like the presents in the MATLAB/Simulink suite.

However, the numeric ODE solvers have different performances depending on which problem they are applied, and some of them are better qualified to solve the sugarhouse ODE simulation.

1. PROCESS DESCRIPTION²

1.1 Upstream & downstream processes

A basic description of the flowsheet for the production of beet sugar is the following (see figure 1). The beets are first washed and sliced to increase the surface for the extraction of sugar. This is carried out in the Extraction Station, where the *raw juice* is obtained. This has to be clarified to reduce the amount of impurities. This is done in the Juice Purification house, where the colored impurities are reduced using methane and a solution of CaCO_3 . The product, called *thin juice*, is a sugar solution with low level of impurities, called non-sugars. The solution is now ready to be concentrated in order to crystallize the sugar.

The concentration is completely done by evaporating water using steam to heat the solution, but in two stages: a first concentration in a five or six-effect evaporator in continuous mode, which produces a high concentrated sugar solution, the *thick juice*; and a final concentration in the sugarhouse. It is important to note that the necessary steam for the sugarhouse is produced in the evaporators, making these two stages more interrelated than ever.

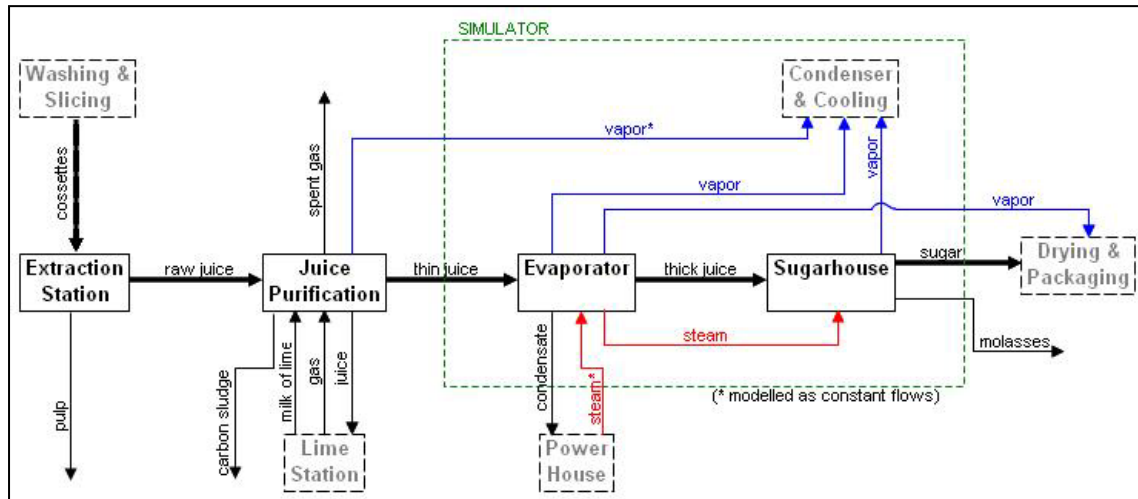

Figure 1: Plant flowsheet.

The final product of the sugarhouse, the sugar, is then sent to a final drying stage and packaging for storage or selling.

1.2 Auxiliary houses

A lot of venting vapor is produced in the extraction of sugar from beets. The main source is the removed water from the crystallizers in the sugarhouse, but also the evaporators and even the Juice Purification station have their quota. All this vapor is removed using vacuum (about 0.25 – 0.30 bar), which is produced by cooling and condensing the water in a series of rotary vacuum pumps. These pumps are the Condensing & Cooling house.

The Power house provides the necessary heating fluid (steam) to the evaporators, and recycles the condensed water coming from them.

The Lime station has the task of generate the utilities (milk of lime and gas) needed to clarify the juice.

1.3 The sugarhouse

Since the simulation will be centered in the sugarhouse operation, this production stage will be described in more detail (see figure 2).

The sugarhouse is comprised by three Stations: A, B and C (or Ep). The sugar is produced in stations A and B, working in parallel. Station C is to recover whatever un-crystallized sugar is left by station B and recycle it to station A.

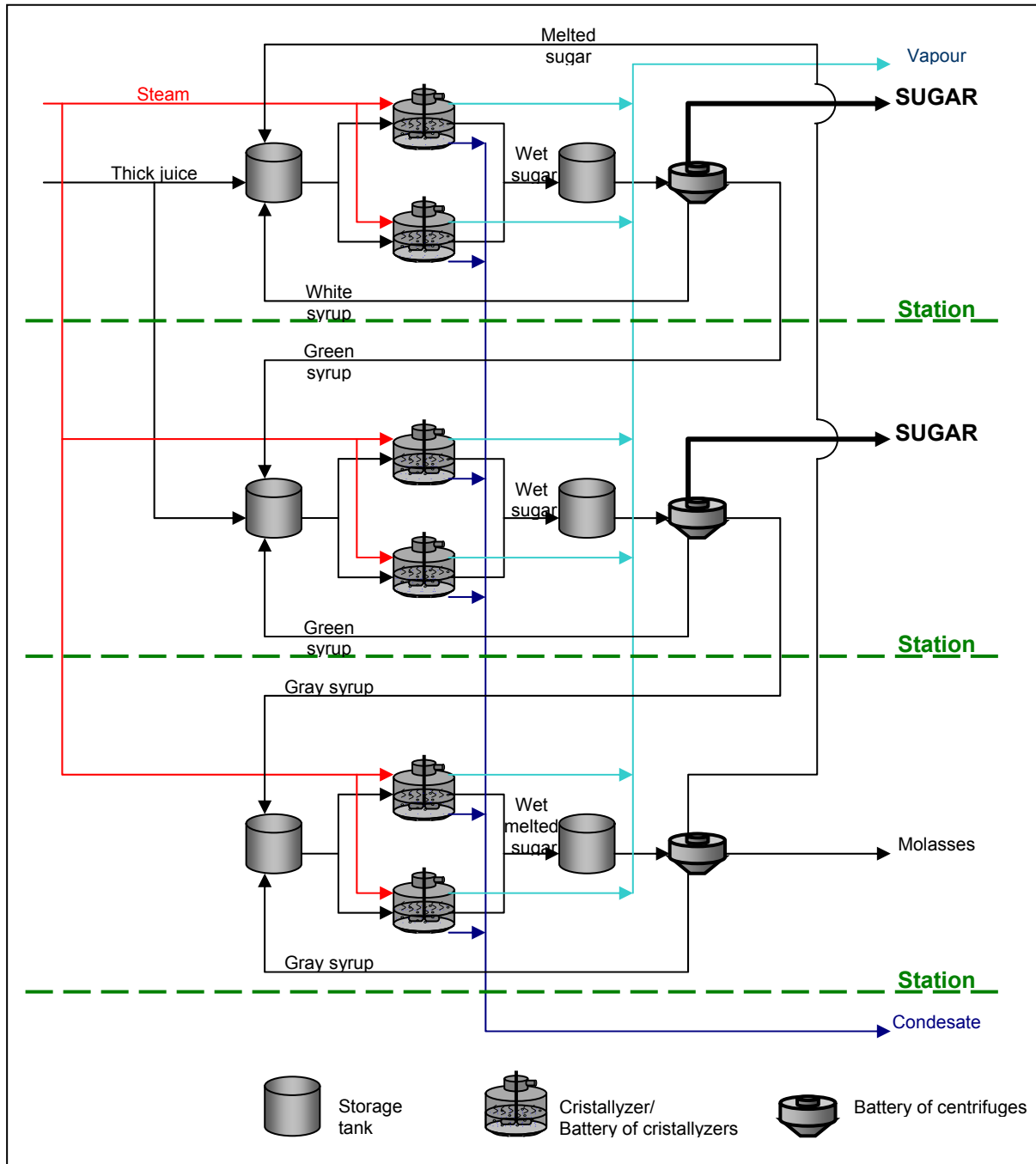

Figure 2. Sugarhouse flowsheet.

The thick juice coming from the evaporators is divided in two flows. Two thirds of the juice are fed to station A and the rest to station B. In station A, before being fed to the crystallizers the juice is stored in a tank, this is necessary to bridge the difference between the continuous evaporators and the batch crystallization, and to blend the two recycle flows.

The crystallizers are the most important units in the sugarhouse. In station A there are 9 crystallizers working in parallel with out-of-phase cycles. This is done to make the overall operation smoother, but mainly because there are not enough utilities (steam and vacuum) to make them work at the same time at full capacity.

The batch cycle has several steps. First it is fed with juice until a set mass is reached; this is done to cover the heating area. The second step is a preconcentration to a set sugar concentration; no juice is fed but the steam valve is open to maximum and the vacuum pressure inside the crystallizer is set to a determined value. This has the objective of create the first crystals in the juice. The next step is crucial and the most thoroughly studied: the boiling and concentration. Due to crystal final size, shape and color considerations, it has to be done following a precise sugar or total solid concentration path. In the present plant this is done with a set-point path for the steam flow and for the vacuum pressure, and using the juice feeding to follow the set path of sugar crystallization. This will carry the volume of solution inside to the nominal crystallizer capacity. In that point the sugar solution has concentrated and crystallized to solid wet sugar. The final cycle steps are discharging the sugar and readying the crystallizer for the following cycle.

The total duration of the cycle can vary greatly (150-230 minutes). The longest step is the boiling and concentration; when the steam supply or the vacuum pressure cannot comply with their set-point paths the step takes more time to complete, in order to follow the set-point path for the sugar concentration.

The wet sugar is collected in the sink tank, and from there is sent to the battery of batch centrifuges to dry the sugar. There are 4 centrifuges and they separate the sugar from the liquid that is around the sugar crystal. This *liquor* still has a lot of sugar and must be treated to recover it. Two kinds of liquor are obtained, the first, with a lower content of non-sugar, is called *white syrup* and is sent to the storage tank located before the crystallizer. The second, with more impurities and sugar content, is called *green syrup* and is sent forward to station B. What is left after the liquor extraction is the final product: sugar. The centrifuges' cycle is very short (4 minutes) compared to the crystallizers' one and can be considered as continuous.

Station B is very similar to station A. It has also 9 crystallizers and 4 centrifuges, these units are identical to the ones in station A, but differ slightly in the set points and in the concentrations considerations. One third of the sugar is produced here. The centrifuges produce also two kinds of liquor: the green syrup is recycled inside the station B and the *gray syrup*. This last liquor, albeit with a high level of non-sugars, has still a lot of sugar and is sent to station C to recover it.

Station C has only 6 crystallizers, they are special units, prepared to treat high level of impurities and their final product is not wet sugar, but a concentrated sugar solution, called *melted*

sugar, that after being treated in the centrifuges is recycled to station A. From the centrifuges are also obtained a flow of gray syrup that is recycled inside station C, and the *molasses* which are the final impurities.

1.4 Simulator scope

The main objective of the simulator is to reproduce the behavior of the sugarhouse, but this stage is so interrelated to the evaporators that a simple, low detail, model of them must be included to study how disturbances originated in this stage affect the sugarhouse. Another utility that is often not available (in the level required by the sugarhouse), is the vacuum to remove the vapor inside the crystallizers. Because of this, also a simple model of the Cooling & Condensing house has to be included in the simulator.

2. MODELING

Below are presented the differential and algebraic equations for each unit. They are mainly empirical^{1,2} in their origins, so, some assumptions must be made and they are listed.

2.1 Storage tanks

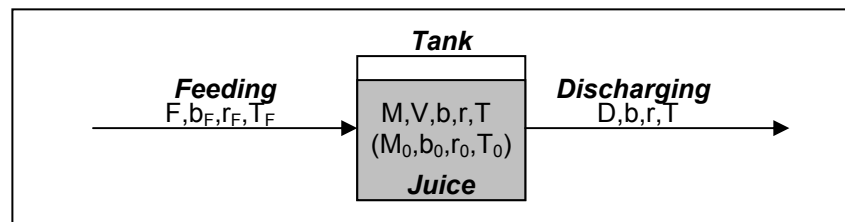

Figure 3. Storage tank model.

2.1.1 Variables

States associated to differential equations

$$x^T = [M, M_S, M_{NS}, H] \quad (1)$$

States associated to algebraic equations

$$w^T = [M_w, b, r, T, V, \rho, b_F, r_F, T_F, H_F] \quad (2)$$

2.1.2 Differential equations

Total tank mass temporal derivative

$$\frac{dM}{dt} = F - D \quad (3)$$

Tank sugar mass temporal derivative

$$\frac{dM_S}{dt} = \frac{b_F F - bD}{100} \quad (4)$$

Tank non-sugars temporal derivative

$$\frac{dM_{NS}}{dt} = \frac{r_F F - rD}{100} \quad (5)$$

Tank enthalpy temporal derivative

$$\frac{dH}{dt} = H_F F - \frac{H}{M} D \quad (6)$$

2.1.3 Algebraic equations

Water mass in tank

$$M - M_S - M_{NS} - M_W = 0 \quad (7)$$

Weight sugar percentage (brix) in tank

$$bM - 100M_S = 0 \quad (8)$$

Weight non-sugars percentage in tank

$$rM - 100M_{NS} = 0 \quad (9)$$

Volume of juice in tank

$$V\rho - M = 0 \quad (10)$$

Juice density definition

$$\rho - (f_{\rho 1} b^2 + f_{\rho 2} b + f_{\rho 3}) = 0 \quad (11)$$

Juice temperature definition

$$H - M[(f_{H1} + f_{H2} b)T + f_{H3} b + f_{H4}] = 0 \quad (12)$$

Feed flow enthalpy per ton

$$H_F - [(f_{H1} + f_{H2} b_F)T_F + f_{H3} b_F + f_{H4}] = 0 \quad (13)$$

2.1.4 Assumptions

- Perfect mixing and stirring.
- No evaporation.
- No heat losses.

2.2 Crystallizers

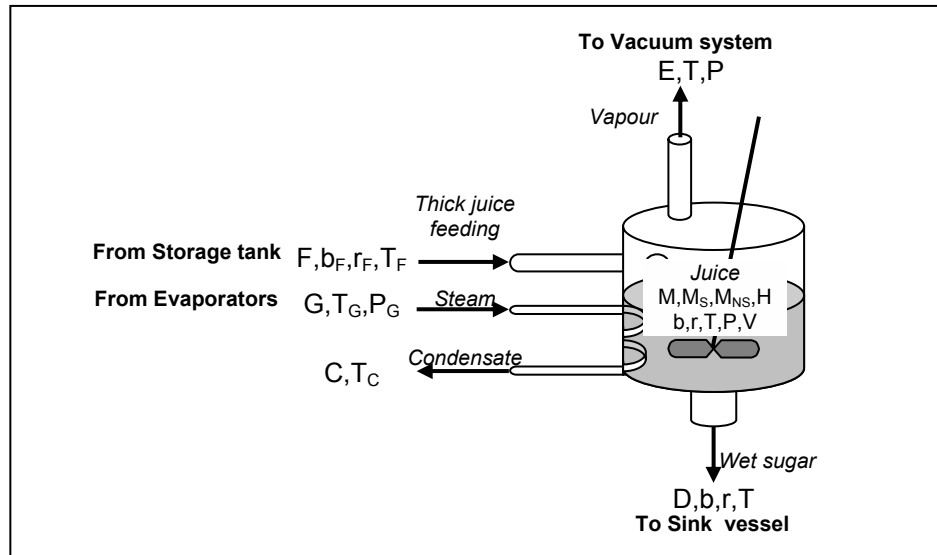

Figure 4. Crystallizer model.

2.2.1 Variables

States associated to differential equations

$$x^T = [M, M_S, M_{NS}, H] \quad (14)$$

States associated to algebraic equations

$$w^T = [M_W, b, r, T, V, \rho, T_B, T_{SAT}, \Delta T_B, Q, Q_{FTB}, \Delta H_V, E, E_{EST}, H_F, H_E, b_{PROF}, G_{PROF}, P_{PROF}, KNIV] \quad (15)$$

Control variables

$$u^T = [F, G, P, D] \quad (16)$$

Parameters

$$p^T = [F_{MAX}, b_F, r_F, T_F, G_{MAX}, T_G, P_G, P_{MIN}, D_{MAX}, f_{\rho 1}, f_{\rho 2}, f_{\rho 3}, f_{T01}, f_{T02}, f_{T03}, f_{T04}, f_{T05}, f_{T06}, f_{T07}, f_{T08}, f_{T09}, f_{T10}, f_{T11}, f_{H1}, f_{H2}, f_{H3}, f_{H4}, f_{G1}, f_{G2}, f_{G3}] \quad (17)$$

Set points (parameters)

$$p^{*T} = [NIV_1, NIV_2, DONIV, NIV_{DMP1}, NIV_{DMP2}, m_{DMP}, a_{DMP}, NIV_{RF1}, NIV_{RF2}, m_{RF}, a_{RF}, NIV_{VAC1}, NIV_{VAC2}, m_{VAC}, a_{VAC}] \quad (18)$$

2.2.2 Differential equations

Total juice mass temporal derivative

$$\frac{dM}{dt} = F - E - D \quad (19)$$

Juice sugar mass temporal derivative

$$\frac{dM_S}{dt} = \frac{b_F F - bD}{100} \quad (20)$$

Juice impurities temporal derivative

$$\frac{dM_{NS}}{dt} = \frac{r_F F - rD}{100} \quad (21)$$

Juice enthalpy temporal derivative

$$\frac{dH}{dt} = H_F F + Q - H_E - \frac{H}{M} D \quad (22)$$

2.2.3 Auxiliary equations

Water mass in juice

$$M - M_S - M_{NS} - M_W = 0 \quad (23)$$

Weight sugar percentage (brix) in juice

$$bM - 100M_S = 0 \quad (24)$$

Weight impurities percentage in juice

$$rM - 100M_{NS} = 0 \quad (25)$$

Volume of juice in crystallizer

$$V\rho - M = 0 \quad (26)$$

Juice density definition

$$\rho - (f_{\rho 1} b^2 + f_{\rho 2} b + f_{\rho 3}) = 0 \quad (27)$$

Juice temperature definition

$$H - M[(f_{H1} + f_{H2} b)T + f_{H3} b + f_{H4}] = 0 \quad (28)$$

Juice boiling temperature definition

$$T_B - (T_{SAT} + \Delta T_B) = 0 \quad (29)$$

Water saturation temperature definition

$$T_{SAT} - (159.52P^{0.1759} - 59.96^\circ\text{C}) = 0 \quad (30)$$

Boiling point elevation in sugar solution (juice)

$$\Delta T_B - \left\{ \exp(f_{T01} + f_{T02}b + f_{T03}b^2) + f_{T04} + \left[\exp(f_{T05} + f_{T06}b + f_{T07}b^2) + f_{T08} \right] \frac{T_{SAT}}{100} + \exp(f_{T09} + f_{T10}b + f_{T11}b^2) \frac{T_{SAT}^2}{10000^\circ\text{C}} \right\} = 0 \quad (31)$$

Feed flow enthalpy per ton

$$H_F - [(f_{H1} + f_{H2}b_F)T_F + f_{H3}b_F + f_{H4}] = 0 \quad (32)$$

Heat given by steam flow per minute

$$Q - 1.5G[f_{G1} + f_{G2}T_G - f_{G3}(6T_G - T/8)] = 0 \quad (33)$$

Heat flow needed to heat the feed flow to T_B

$$Q_{FTB} - F[(f_{H1} + f_{H2}b_F)(T_B - T_F)] = 0 \quad (34)$$

Vapor formation rate

$$\Delta H_V E - (Q - Q_{FTB}) \left\{ 0 + \frac{2-0}{1 + \exp[-1(T - T_B)]} \right\} \left\{ 0 + \frac{2-0}{1 + \exp[-10^8(Q - Q_{FTB})]} \right\} = 0 \quad (35)$$

Juice latent heat per ton (calculated for pure water)

$$\Delta H_V - (2519.9 \frac{J}{kg} - 2.5652 \frac{J}{kg^\circ\text{C}} T) = 0 \quad (36)$$

Vapor enthalpy per ton

$$H_E - (f_{G1}T + f_{G2}) = 0 \quad (37)$$

Instant juice volume change definition

$$KNIV - (V - NIV_1) = 0 \quad (38)$$

Steam flow profile as a function of KNIV

$$G_{PROF} - \left[NIV_{DMP1} - a_{DMP} * NIV_{DMP1} \left(\frac{KNIV}{DONIV} \right)^{m_{DMP}} \right] = 0 \quad (39)$$

Vacuum profile as a function of KNIV

$$P_{PROF} - \left[NIV_{VAC1} - a_{VAC} * NIV_{VAC1} \left(\frac{KNIV}{DONIV} \right)^{m_{VAC}} \right] = 0 \quad (40)$$

Sugar concentration profile as a function of KNIV

$$b_{PROF} - \left[NIV_{RF1} - a_{RF} * NIV_{RF1} \left(\frac{KNIV}{DONIV} \right)^{m_{RF}} \right] = 0 \quad (41)$$

Estimated vapor formation rate with $G=G_{PROF}$ and $P=P_{PROF}$

$$\Delta H_V E_{EST} - 1.5G_{PROF} [f_{G1} + f_{G2}T_G - f_{G3}(6T_G - T/8)] = 0 \quad (42)$$

2.2.4 Controller equations

The controller works performing a series of step. Each step uses its own set of equations for feed flow, steam flow, vacuum pressure and discharge flow.

Step 0: Stand by

$$\begin{aligned} \text{Feed flow:} \quad & F - 0 = 0 \\ \text{Steam flow:} \quad & G - 0 = 0 \\ \text{Vacuum pressure:} \quad & P - 1 \text{ atm} = 0 \\ \text{Discharge flow:} \quad & D - 0 = 0 \end{aligned} \quad (43)$$

Step 1: Filling and covering of heating surface

$$\begin{aligned} \text{Feed flow:} \quad & F - F_{MAX} = 0 \\ \text{Steam flow:} \quad & G - 0 = 0 \\ \text{Vacuum pressure:} \quad & P - 1 \text{ atm} = 0 \\ \text{Discharge flow:} \quad & D - 0 = 0 \end{aligned} \quad (44)$$

Step 2: Preconcentration

$$\begin{aligned} \text{Feed flow:} \quad & F - 0 = 0 \\ \text{Steam flow:} \quad & G - G_{MAX} = 0 \\ \text{Vacuum pressure:} \quad & P - 0.3 \text{ atm} = 0 \\ \text{Discharge flow:} \quad & D - 0 = 0 \end{aligned} \quad (45)$$

Step 3: Boiling

$$\begin{aligned} \text{Feed flow:} \quad & F \left\{ \frac{b_F - b}{M} + \frac{aS_1m}{\rho^2 DONIV} \left(\frac{KNIV}{DONIV} \right)^{m-1} \left[\rho + \frac{b_F - b}{M} (2f_{\rho_1}b + f_{\rho_2}) \right] \right\} + \\ & + \frac{aS_1m}{\rho^2 DONIV} \left(\frac{KNIV}{DONIV} \right)^{m-1} \left[\frac{E_{EST}b}{M} (2f_{\rho_1}b + f_{\rho_2}) - \rho E_{EST} \right] + \frac{E_{EST}b}{M} = 0 \end{aligned}$$

$$\begin{aligned} \text{Steam flow:} \quad & G - G_{PROF} = 0 \\ \text{Vacuum pressure:} \quad & P - P_{PROF} = 0 \\ \text{Discharge flow:} \quad & D - 0 = 0 \end{aligned} \quad (46)$$

Step 4: Discharging

$$\begin{aligned}
\text{Feed flow:} & \quad F - 0 = 0 \\
\text{Steam flow:} & \quad G - 0 = 0 \\
\text{Vacuum pressure:} & \quad P - 0 = 0 \\
\text{Discharge flow:} & \quad D - D_{MAX} = 0
\end{aligned}
\tag{47}$$

2.2.5 Assumptions

- Perfect control in juice flow, steam flow and vacuum.
- Perfect mixing and stirring.
- No heat losses.
- Steam is always at saturation point.
- Same T in liquid and vapor phases inside the crystallizer.
- P in vapor phase is equal to vacuum pressure.
- Immediate transportation of produced vapor to vacuum system.
- Immediate transportation of evaporated water from near heating area to vapor phase.
- ΔH_v calculated for pure water.
- No vapor holdup in gas phase.

3. ODE SOLVERS IN THE MATLAB/SIMULINK[®] SUITE**3.1 Variable-step solvers**

The Simulink suite has many ODE solvers. They are divided mainly in variable-step and fixed step solvers. Variable step solvers adapt the size of the time increases in order to simulate at the fastest possible speed without losing significant behaviors. Each one of the solvers is based in a different numerical method, and their performance depends on the characteristics of the ODE problem. Below is a description of the different available solvers.

ode45 is based on an explicit Runge-Kutta formula, the Dormand-Prince pair³. It is a one-step solver; that is, in computing $y(t_n)$, it needs only the solution at the immediately preceding time point, $y(t_{n-1})$. In general, ode45 is the best solver to apply as a "first try" for most problems.

ode23 is also based on an explicit Runge-Kutta pair of Bogacki and Shampine⁴. It may be more efficient than ode45 at crude tolerances and in the presence of mild stiffness. ode23 is a one-step solver.

ode113 is a variable order Adams-Bashforth-Moulton PECE³ solver. It may be more efficient than ode45 at stringent tolerances. ode113 is a multistep solver; that is, it normally needs the solutions at several preceding time points to compute the current solution.

ode15s is a variable order solver based on the numerical differentiation formulas (NDFs). These are related to but are more efficient than the backward differentiation formulas, BDFs

(also known as Gear's method). Like ode113, ode15s is a multistep method solver. If you suspect that a problem is stiff or if ode45 failed or was very inefficient, try ode15s.

ode23s is based on a modified Rosenbrock³ formula of order 2. Because it is a one-step solver, it may be more efficient than ode15s at crude tolerances. It can solve some kinds of stiff problems for which ode15s is not effective.

ode23t is an implementation of the trapezoidal rule using a "free" interpolant. Use this solver if the problem is only moderately stiff and you need a solution without numerical damping.

ode23tb is an implementation of TR-BDF2, an implicit Runge-Kutta formula with a first stage that is a trapezoidal rule step and a second stage that is a backward differentiation formula of order two. By construction, the same iteration matrix is used in evaluating both stages. Like ode23s, this solver may be more efficient than ode15s at crude tolerances.

discrete (variable-step) is the solver to utilize when the model has no continuous states.

3.2 Stiffness

There are many definitions of stiffness. Here, we use the given by Shampine⁴ (1994). For a stiff problem, solutions can change on a time scale that is very short compared to the interval of integration, but the solution of interest changes on a much longer time scale. Methods not designed for stiff problems are ineffective on intervals where the solution changes slowly because they use time steps small enough to resolve the fastest possible change.

4. ODE SOLVER PERFORMANCES AND SELECTION

For the present problem, it is obvious that we cannot use the discrete variable step solver because the model has continuous states. Furthermore, it was decided not to model it in discrete time to make it more real when it comes to test scheduling and control strategies.

The model also presents heavy non-linearities, this happens especially in equations (30), (35) and (46). But all the ODE variable step solvers in the Simulink suite have very similar performances in relation to non-linearities; they adjust automatically the integration step size in order to capture the significant behaviors.

Equation (35) has discrete changes modeled as continuous. The two sigmoid terms are to assure that there is no vapor formation when T is lower than the boiling temperature, and when the heat given by the steam is less than the energy needed to heat the incoming juice to the boiling temperature. Although this modeling technique reduces greatly the stiffness of the equation it is still very stiff. Equation (35) is a crucial part in the model of the crystallizers, so, this stiffness is present in almost every unit in the sugarhouse. The interrelation of these units and the great number of recycles only increases the importance of this stiffness. Another source of stiffness is the batch cycle itself. While in three of the four steps (Filling, Preconcentration and Discharging) the values of juice feeding flow, steam flow and/or discharging flow are set to maximum; in the most important one (Boiling & Concentration) they change very slowly in time.

All these considerations reduce the list of suitable solvers to ode15s and ode23s. ode23s is very accurate but also very slow, and the total simulation time increases greatly. It took around 350 minutes to simulate 3000 minutes^(*), depending on the initial conditions and disturbances simulated.

Solver ode15s is faster than ode23s, but originally it could not simulate all the significant behaviors of the model, so, this was re-escalated in order to increase the efficiency of the solver. Also, a lot of study was done to increase the linearity in equations (27), (28) and (33). It was discovered that in the range where this model works, these equations present quite linear behavior, so, they were adjusted to take advantage of that. With these changes applied, ode15s takes around 70 minutes to simulate 3000 minutes^(*).

Solver ode45 was also studied, because it can handle middle stiffness and is very fast, but the level of stiffness present in the model make it crash shortly into the simulation time.

After these considerations the chosen ODE solver was **ode15s**.

^(*) Hardware: Pentium III at 996 MHz with 256MB of RAM. Software: MATLAB 6.0/Simulink 4.0.

5. CONCLUSIONS & FUTURE WORK

A dynamic model of a sugarhouse, suitable for simulation, has been developed. This model will provide a reliable test bed for scheduling and control techniques.

The study of the different ODE solvers present in Simulink, and the numeric formulae they are based provided a better insight of dynamic simulations, and allowed to increase the performance and integration speed of the chosen solver, **ode15s**.

To make it suitable for operator training simulation, a user-friendly interface is being developed. Also, work will be done to compile the model in order to make it faster (Real-Time Workshop in the MATLAB suite).

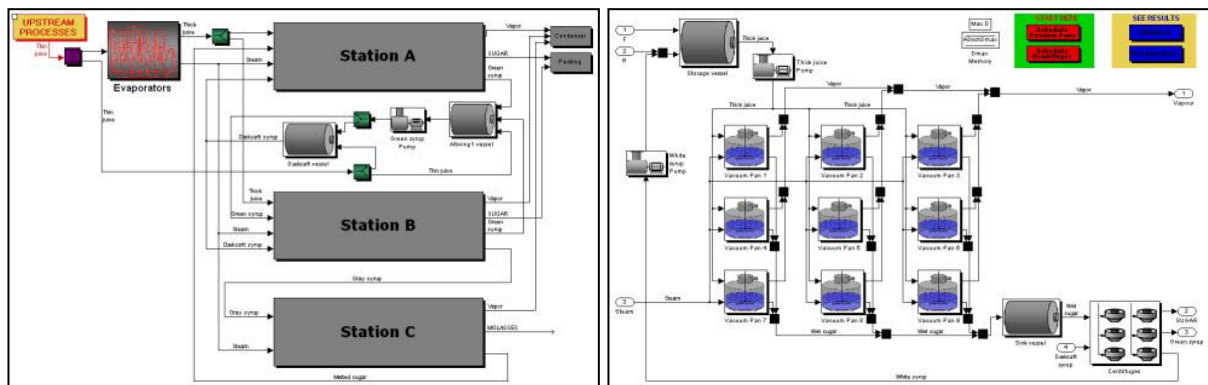

Figure 5. Main screen and Station A screen of the Simulink model.

6 REFERENCES

- [1] K. Urbaniec, *Heat economy control in beet sugar plants*, Elsevier Science Publishers, Sugar Technology Reviews Vol. X., 1983.

- [2] U.M. Ascher and L.R. Petzold, *Computer methods for ordinary differential equations and differential-algebraic equations*, Society for Industrial and Applied Mathematics, 1998.
- [3] H. Jansdorf, *Sukkerproduktion*, Danisco Sugar, 1997.
- [4] L.F. Shampine, *Numerical solution of ordinary differential equations*, Chapman & Hall, 1994.

APPENDIX A - NOMENCLATURE

- a_{DMP} []: ramp factor in steam profile
 a_{RF} []: ramp factor in brix degrees' profile
 a_{VAC} []: ramp factor in vacuum profile

 b [Tn sugar/Tn]: weight sugar percentage in juice
 b_F [Tn sugar/Tn]: weight sugar percentage in feed flow
 b_{PROF} [Tn sugar/Tn]: set points profile for brix degrees (as a function of volume)

 D [Tn/min]: discharge flow
 D_{MAX} [Tn/min]: maximum available discharging
 $DONIV$ [m³]: total juice volume change during boiling

 E [kg/min]: vapor formation rate
 E_{EST} [kg/min]: estimated vapor formation rate

 F [kg/min]: feed flow
 F_{MAX} [kg/min]: maximum feed flow capacity
 f_{G1} [MJ/Tn°C]: factor in vapor enthalpy equation
 f_{G2} [MJ/Tn]: factor in vapor enthalpy equation
 f_{H1} [MJ/Tn°C]: factor in sugar solution enthalpy eq.
 f_{H2} [MJ/Tn°C]: factor in sugar solution enthalpy eq.
 f_{H3} [MJ/Tn]: factor in sugar solution enthalpy eq.
 f_{H4} [MJ/Tn]: factor in sugar solution enthalpy eq.
 f_{T01} []: factor in boiling point elevation equation
 f_{T02} []: factor in boiling point elevation equation
 f_{T03} []: factor in boiling point elevation equation
 f_{T04} [°C]: factor in boiling point elevation equation
 f_{T05} []: factor in boiling point elevation equation
 f_{T06} []: factor in boiling point elevation equation
 f_{T07} []: factor in boiling point elevation equation
 f_{T08} []: factor in boiling point elevation equation
 f_{T09} []: factor in boiling point elevation equation
 f_{T10} []: factor in boiling point elevation equation
 f_{T11} []: factor in boiling point elevation equation
 $f_{\rho 1}$ []: factor in density equation
 $f_{\rho 2}$ []: factor in density equation
 $f_{\rho 3}$ [Tn/m³]: factor in density equation

 G [kg/min]: steam flow
 G_{PROF} [kg/min]: set points profile for steam flow (as a function of volume)
 G_{MAX} [kg/min]: maximum available steam flow

 H [MJ]: juice enthalpy
 H_F [MJ/Tn]: feed enthalpy per kilogram
 H_E [MJ/Tn]: vapor enthalpy per kilogram

 $KNIV$ [m³]: instant juice volume change during boiling

 M [Tn]: juice mass
 M_{NS} [Tn]: mass of impurities in juice
 M_S [Tn]: mass of sugar in juice
 M_W [Tn]: mass of water in juice

 m_{DMP} []: exponent in steam profile
 m_{RF} []: exponent in brix degrees profile
 m_{VAC} []: exponent in vacuum profile

 NIV_1 []: starting volume for boiling
 NIV_2 []: ending volume for boiling
 NIV_{DMP1} [kg/min]: starting value in steam profile
 NIV_{DMP2} [kg/min]: ending value in steam profile
 NIV_{RF1} []: starting value in brix degrees profile
 NIV_{RF2} []: ending value in brix degrees profile
 NIV_{VAC1} [atm]: starting value in vacuum profile
 NIV_{VAC2} [atm]: ending value in vacuum profile

 P [atm]: Vacuum pressure in crystallizer
 P_G [atm]: Steam flow pressure
 P_{PROF} [atm]: set points profile for vacuum (as a function of volume)
 P_{MIN} [atm]: minimum available vacuum pressure

 Q [MJ/min]: heat given by steam
 Q_{FTB} [MJ/min]: heat needed to warm the feed flow to T_B

 r [Tn non-sugars/Tn]: weight impurities percentage in juice
 r_F [Tn non-sugars/Tn]: weight impurities percentage in feed flow

 T [°C]: juice temperature
 T_B [°C]: juice boiling temperature
 T_F [°C]: feed flow temperature
 T_G [°C]: steam flow temperature
 T_{SAT} [°C]: water saturation temperature

 V [m³]: juice volume

 ΔH_V [MJ/Tn]: Latent juice heat (calculated for pure water)
 ΔT_B [°C]: boiling point elevation in sugar solution (juice)
 ρ [Tn/m³]: juice density